



INBEST

CUTTER BARS



The Best Investment For Your Workshop

The new **InBest** range of cutter bars has been developed and constructed to satisfy all cutting requirements of a wide range of graphic materials; covering from the most delicate flexible material to any semi-rigid material.

The unique feature of using a linear bearing system to guide the cutting head guarantees an excellent performance and extreme precision, unmatched by any other cutter in the market.

All InBest models are available in five different sizes:

110 cm (44"), 160 cm (63"), 210 cm (82"), 260 cm (102") and 320 cm (126").

- **HIGH ACCURACY & VERSATILITY!**
- **ROBUSTNESS & USER-FRIENDLY!**

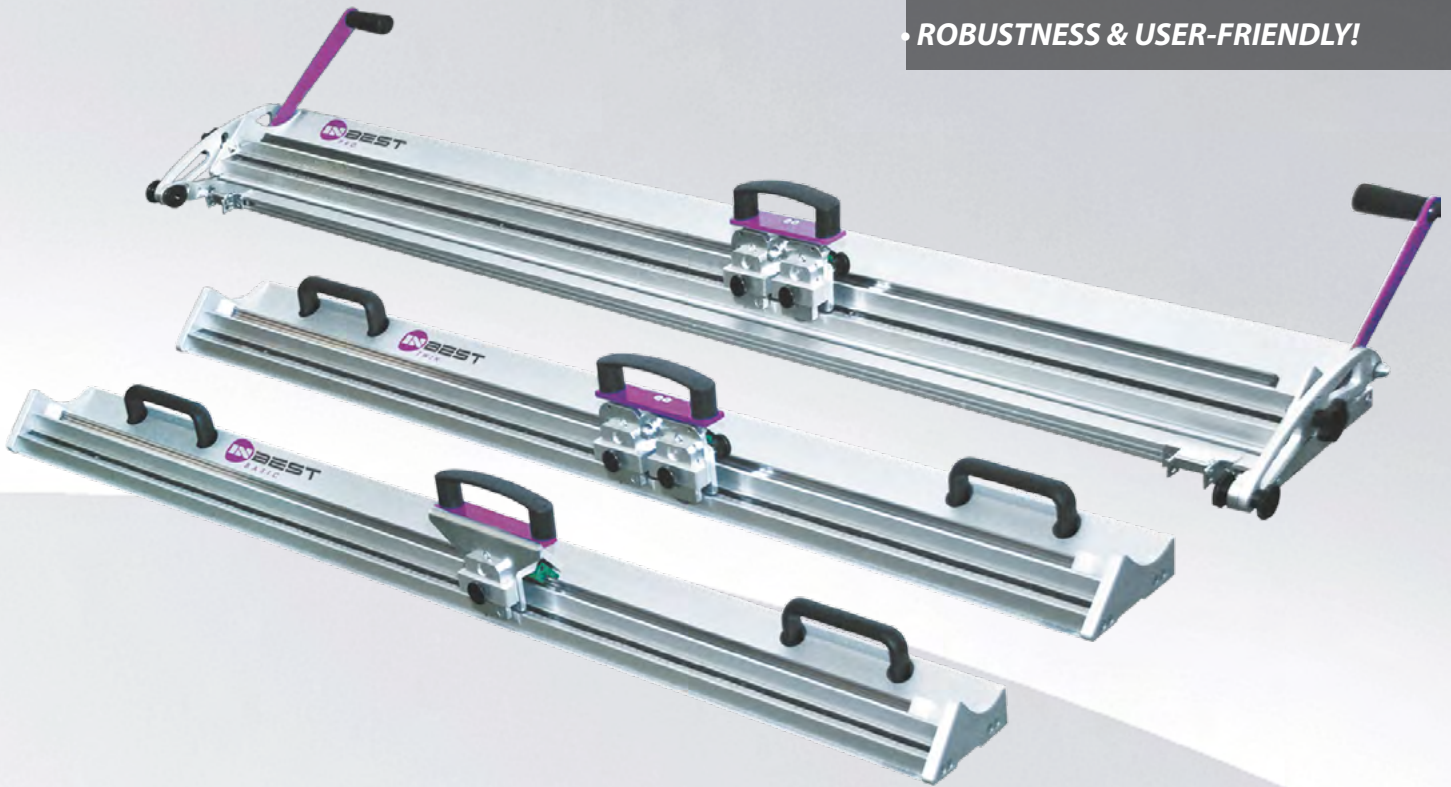

SEMI-RIGIDS Cutting Head

Up to 13 mm

(Included)

Ref. 45 22 95



CIRCULAR BLADE Cutting Head

Flexible materials

(Included)

Ref. 45 22 96



ACRYLIC Cutting Head

Up to 4 mm

(Accessory)

Ref. 45 22 92



REVERSE Cutting Head

Cut from right to left

(Accessory)

Ref. 45 22 93



EXTRA BLADE Cutting Head

Up to 20 mm

(Accessory)

Ref. 45 22 94

INBEST BASIC

The **InBest Basic**, which is the entry-level model, is equipped with a useful and easy-to-use single cutting head holder. The cut requires a soft downward hand pressure.

COMMON FEATURES OF ALL INBEST CUTTERS:

- User-friendly machine easy and simply to install.
- Plastic strip for sight line to visualize the cutting line and avoid guesswork need.
- Cutting thickness up to 20 mm for semi-rigid materials.
- Dust free operation to safely work close to printers.



LINEAR BEARING SYSTEM

The combination of the robust bearing block with the steel linear rail, which is common to all InBest cutters, guarantees an accurate and smooth cutting head movement.



INTERCHANGEABLE CUTTING HEADS

Easy system to quickly interchange the cutting head to use, while the attached handle ensures an extra comfort.

INBEST TWIN

The **InBest Twin** features a revolutionary dual cutting head system to allow the customer to have two different cutting heads installed at one time and block them if required.

The different cutting heads available provide the equipment with a great versatility and productivity.



BLOCKING THE BLADE

Possibility of blocking the blade at the cutting position to facilitate the cut of big sizes. No need of downward hand pressure.



ERGONOMIC HANDLE SYSTEM

Ergonomic handle system to comfortably cut in both directions.

TABLE MOUNT ELEVATOR

Available for **InBest Basic** and **InBest Twin** to offer an easy operation, raising the cutter above the material for positioning the cutting line.

INBEST PRO

The **InBest Pro** adds to the equipment an integrated aluminum base with two different cutting tracks: one with a narrow groove for general purposes, to be used with the knife blade; and other with a built-in cutting strip, to be used with the circular blade.

The **InBest Pro** is also equipped with an integral lift and hold mechanism, which can be used from both sides, to facilitate the material loading. This model must be screwed to a table or a working surface.



INTERCHANGEABLE CUTTING TRACK

Cutting position easily changeable in few seconds through the quick knob system.

FULL LENGTH GRIP STRIPS

Both the cutter and the aluminum base are equipped with full length grip strips to aid clamping and protect printed media.

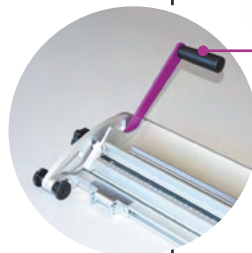

LIFT AND HOLD MECHANISM

Useful and comfortable handle system to raise the cutter bar.

FREE WORKING AREA

Cutter bar can be placed vertically on the side of the bench to free the working area if required.

TABLE MOUNT
ELEVATOR

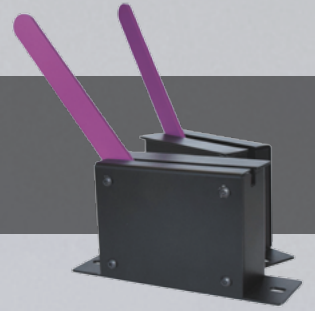

INEXPENSIVE!

REVOLUTIONARY
DUAL CUTTING
HEAD SYSTEM



INDISPENSABLE!

FREE
WORKING
AREA



INCOMPARABLE!



	72 68 02 Basic 110	72 68 03 Basic 160	72 68 04 Basic 210	72 68 05 Basic 260	72 68 06 Basic 320
	72 68 12 Twin 110	72 68 13 Twin 160	72 68 14 Twin 210	72 68 15 Twin 260	72 68 16 Twin 320
Cutting length	110 cm / 44"	160 cm / 63"	210 cm / 82"	260 cm / 102"	320 cm / 126"
Length (A)	138 cm / 55"	188 cm / 74"	238 cm / 93"	288 cm / 113"	348 cm / 137"
Width (B)	15,8 cm / 6,22"				
Weight Basic	9,2 kg / 20 lb	12 kg / 26,4 lb	14,8 kg / 32,6 lb	18 kg / 40 lb	21,7 kg / 47 lb
Peso Twin	9,8 kg / 21,6 lb	12,6 kg / 28 lb	15,4 kg / 34 lb	18,6 kg / 41 lb	26,5 kg / 57 lb
Packing dimensions	154 x 26 x 32 cm	204 x 26 x 32 cm	254 x 26 x 32	304 x 26 x 32 cm	364 x 26 x 32 cm
Packing weight Basic	14 Kg	18 Kg	22,50 Kg	25,50 Kg	30 Kg
Packing weight Twin	14,50 Kg	18,50 Kg	23 Kg	26 Kg	30,50 Kg

	72 68 22 Pro 110	72 68 23 Pro 160	72 68 24 Pro 210	72 68 25 Pro 260	72 68 26 Pro 320
Cutting Length	110 cm / 44"	160 cm / 63"	210 cm / 82"	260 cm / 102"	320 cm / 122"
Length (A)	146 cm / 58"	196 cm / 77"	246 cm / 96"	296 cm / 116"	356 cm / 140"
Width (B)	22,5 cm / 8,86"				
Weight	16 kg / 35 lb	20,5 Kg / 45 lb	26 kg / 57 lb	32 kg / 70.5 lb	45,7 kg / 99 lb
Packing dimensions	154 x 26 x 32 cm	204 x 26 x 32 cm	254 x 26 x 32 cm	304 x 26 x 32 cm	364 x 26 x 32 cm
Packing weight	20 Kg	26 Kg	31 Kg	38 Kg	45 kg

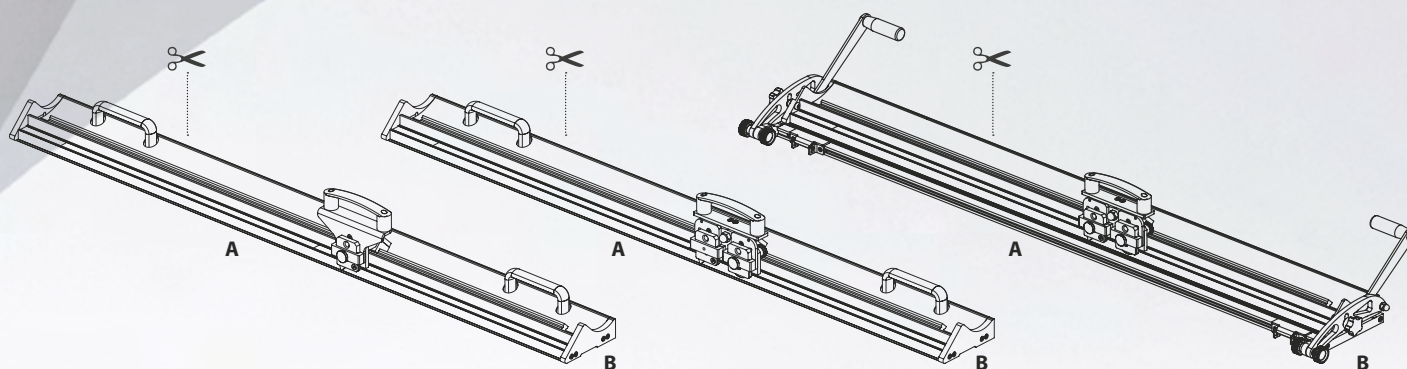

RIGIDS

	Max. Thickness
PVC Foamboard	5 mm / 10 mm **
Acrylics / Plexiglas®	4 mm * / ◇

SEMI-RIGIDS

	Max. Thickness
Foamboard	13 mm / 20 mm *
Cardboard	13 mm / 20 mm *
Honeycomb / Re-board®	13 mm / 20 mm *
Corrugated plastic	13 mm
Passepartout	✓

FLEXIBLES

	Grosor máximo
Fabric / Textiles	✓
Plastic film	✓
Banner materials	✓
Paper	✓
Vinyl	✓
Magnetic sheets	✓

* Optional accessory required. ** The Pro model allows cutting without any problems. In the Basic and Twin models it is possible, but not for daily use. ◇ Score and snap.

ACCESORIOS

Semi-rigids cutting head (included)	45 22 95
Circular blade cutting head (included)	45 22 96
Acrylic cutting head	45 22 92
Reverse cutting head	45 22 93
Extra blade cutting head	45 22 94
Table mount elevator for InBest Basic & Twin (1 set)	45 22 01
Trapezoid blades -100 u-	13 01 30
Circular blade -1 u-	13 01 26
Acrylic scoring blade -5 u-	13 01 47

TABLE FOR INBEST PRO

Table for Inbest Pro, 160 cm	14 22 03
Table for Inbest Pro, 210 cm	14 22 04
Table for Inbest Pro, 260 cm	14 22 05
Table for Inbest Pro, 320 cm	14 22 06

